



# MOUNTING INSTRUCTIONS and PARTS LIST for 16C DEAD LENGTH WORK STOP

The dead length work stop makes it possible to accurately locate and hold parts that have a previously machined shoulder. The soft, machineable stop plates can be bored in your shop to the appropriate size for nearly instantaneous use. The work stop can be mounted on any Hardinge machine that has a A2-5 spindle.

## Mounting Instructions:

1. Bore stop plate "C", Figure 1 to the desired diameter that will provide clearance for the part to be gripped. This may be done on a separate machine.
2. Install the correct size collet (separate item) in the spindle and adjust the gripping pressure as outlined in the operator's manual supplied with the machine.
3. Use a clean shop rag to wipe off the front face, mounting taper, and shoulder of the spindle; the back face and I.D. of work stop mount "A"; and both faces of stop plate "C".
4. Install work stop mount "A" on the spindle using four screws "D".
5. Place stop plate "C" in the mount with the tapered side facing out as shown in Figure 1.
6. Hold the stop plate against the spindle face and snug down four set screws "B". Do not over tighten.

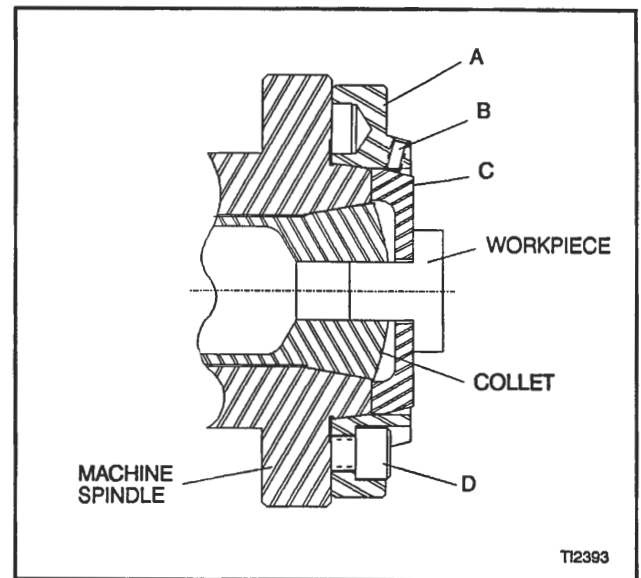

Figure 1 - Dead Length Work Stop

## - NOTE -

After the job is completed, the stop plate can be removed and etched with the job number (not on the locating faces) and stored for future use.

**Hardinge Brothers, Inc.**  
Elmira, New York 14902-1507  
Telephone: 607 734-2281 • Fax: 607 734-3886

# PARTS LIST

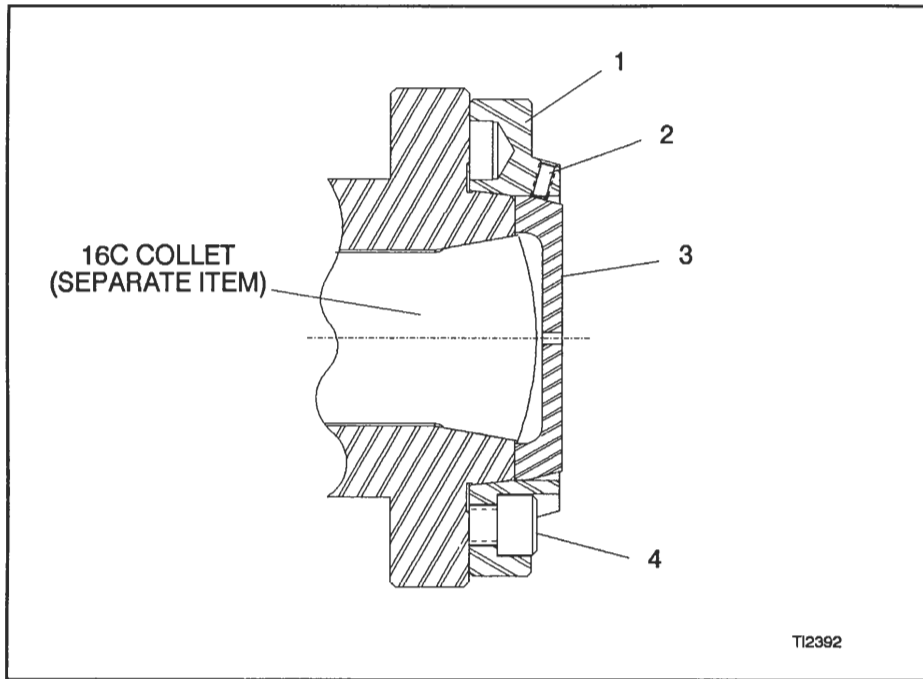

ITEM	PART NUMBER	QUANTITY	DESCRIPTION
-	1311-00-00-000000	1	Stop Mount Assembly (Includes Items 1, 2, and 4)
1	1313-00-00-000000	1	Work Stop Mount
2	570306	4	10-32 x 3/8 Set Screw
3	1315-00-00-000000	1	Work Stop (Set of 3)
4	101216	4	7/16-14 x 1 Skt. Hd. Cap Screw