



Hardinge FlexC™ Dead-Length® Collet System
Style DL — 42mm
Installation Instructions
and Parts Lists

General Safety Information

Before installing the Hardinge® FlexC™ Collet System on your machine tool, thoroughly read this manual and understand the information. If you are uncertain about any of the information, see your immediate supervisor. Also make certain that you understand the information in your machine tool operator's, programmer's and maintenance manuals.

NOTICE

**Damage resulting from misuse, negligence or accidents
is not covered by the Hardinge FlexC warranty.**

Information in this document is subject to change without notice.

**In no event will Hardinge Inc. be responsible for indirect or consequential damage
resulting from the use or application of the product, or any of the information in this document.**

**This product is only to be used by trained machinists skilled
in the use and operation of collet systems and collet chucks on metal cutting machines.**

Safety Requirements to the Turning Machine:

Check to see that the workpiece is properly gripped and seated in the collet head before beginning the machining cycle.

Do not unclamp the workpiece until the machining cycle has come to a complete stop.

Observe all safety precautions indicated in the machine manual when operating the machine including the use of guards and keeping the door closed during machining.

Do not exceed the maximum operating force and rpm for the Hardinge FlexC Collet Systems indicated below:

Maximum operating force: 7,900 lb (35KN)

Maximum RPM: 7000

Product Description and Use:

The Hardinge FlexC style DL Collet System consists of a spindle mount assembly. Vulcanized collet heads and wrenches are purchased separately. The style DL Dead-length® Collet System can be used as a thru-hole for bar work or with a work stop for chucking. The clamping heads consist of hardened steel segments that are joined together by a vulcanization process. Their outstanding characteristics include parallel workpiece clamping, superb accuracy with a minimum of deformation of the work piece, and quick-change capability. If the Hardinge FlexC style DL Collet System is used as a dead-length system the work stop is inserted into the workstop adapter with the part stop wrench included. When part length control is not required the work stop can be removed.

The Hardinge FlexC style DL Collet Systems use a push-to-close design with an axially-fixed collet head. They are ideally suited for sub-spindles to maintain length control during secondary operations. The push-to-close design also avoids axial stress between the spindles. The collet head is fixed in the spindle mount, while the drawbar moves forward and closes the collet head.

CAUTION: Make sure that the workpiece is adequately gripped so that the workpiece will not come loose during the machining process. When clamping very short workpieces, the minimum clamping lengths must be observed. They depend on the selected clamping head size and shape – call Hardinge for guidance. Do not clamp tapered work pieces. In general the collet system should never be rotated without a clamped workpiece. Never rotate the collet system over 2,000 RPM without a clamped workpiece. When actuating the changing wrench, never reach inside the moving parts for risk of severely damaging your hand.

Drawbar Linkup

The Hardinge FlexC Collet System requires a drawbar linkup to mate the specific machine drawbar (varies by machine brand and model) to the FlexC clamping sleeve. This linkup can be ordered from Hardinge or can be made by the customer.

Cleaning and Maintenance

The spindle, collet head and the spindle mount mating surfaces must be cleaned and free of chips and sludge whenever mounting to the spindle or changing out a collet head. Visually inspect collets for tearing or separation of rubber on a regular basis during long job runs and during setup. If you are using a high pressure coolant in your machining processes, you need to inspect the collets more frequently. Do NOT clean an open spindle with an air hose as chips and sludge may be forced into the spindle drawbar area. Clean and lubricate all moving parts with Chevron Ultra-Duty EP NLGI 2, Dow Corning BR-2-Plus, or Kluber ALTEMP Q NB 50 grease. Store all unused products properly to prevent corrosion and keep free of dust and environmental particles.

Check to see that all mounting screws are in good condition and replace when worn. All components must be replaced with original Hardinge replacement parts.

A2-5 Assembly #V42-5DL05400 Parts List:

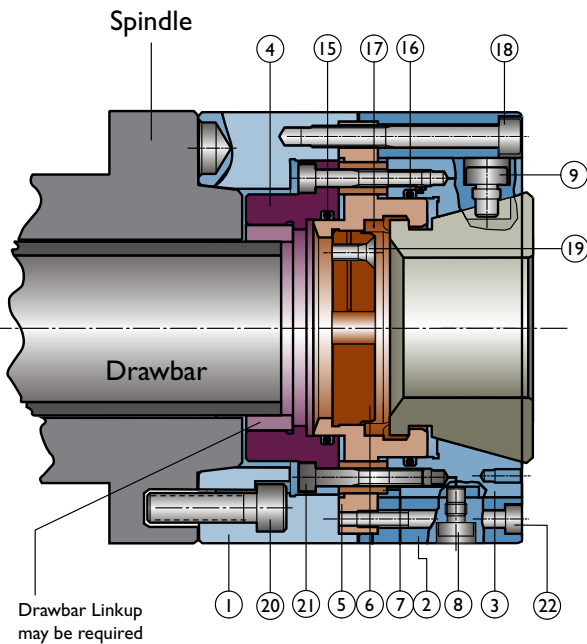

ITEM	PART NUMBER	QTY	DESCRIPTION
1	V42-5DL05401	1	Chuck Flange
2	V42-5DL05402	1	Chuck Body
3	V42-5DL05403	1	Collet Seat
4	V42-5DL05404	1	Drawbar Adapter (separate item)*
5	V42-5DL05405	1	Coupling Stop
6	V42-5DL05406	1	Part Stop
7	V42-5DL05407	6	Spacer
8	V42-00201	1	Key for Collet Seat
9	V42-01007	1	Key for Collet Head
10	V42-5DL05410	1	Part Stop Wrench
15	CE-0006003	1	O-Ring 60mm ID, 3mm C's
16	OR-0004650	1	O-Ring 27/8 ID, 1/8mm C's
17	036911701	1	Seal
18	MS0103831	6	M8 x 90 SHCS (30ft-lb/41Nm)
19	MS0313617	1	M6 x 16 Flat Head Screw
20	MS0124020	4	M10 x 30 Low Head SHCS (40ft-lb/54Nm)
21	MS0103622	6	M6 x 40 SHCS
22	MS0103628	2	M6 x 70 SHCS

A2-6 Assembly #V42-6DL05500 Parts List:

SECTION A-B

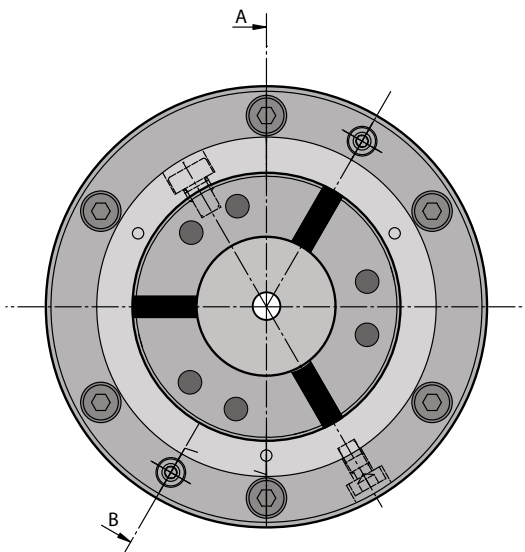

ITEM	PART NUMBER	QTY	DESCRIPTION
1	V42-6DL05501	1	Chuck Flange
2	V42-5DL05402	1	Chuck Body
3	V42-5DL05403	1	Collet Seat
4	V42-5DL05404	1	Drawbar Adapter (separate item)*
5	V42-5DL05405	1	Coupling Stop
6	V42-5DL05406	1	Part Stop
7	V42-5DL05407	6	Spacer
8	V42-00201	1	Key for Collet Seat
9	V42-01007	1	Key for Collet Head
10	V42-5DL05410	1	Part Stop Wrench
15	CE-0006003	1	O-Ring 60mm ID, 3mm C's
16	OR-0004650	1	O-Ring 27/8 ID, 1/8mm C's
17	036911701	1	Seal
18	MS0103831	6	M8 x 90 SHCS (30ft-lb/41Nm)
19	MS0313617	1	M6 x 16 Flat Head Screw
20	MS0104223	4	M12 x 45 SHCS (60ft-lb/81Nm)
21	MS0103622	6	M6 x 40 SHCS
22	MS0103628	2	M6 x 70 SHCS

I40mm Assembly #V42-I40DL04400 Parts List:

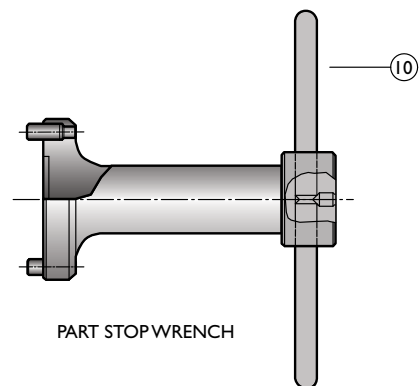

ITEM	PART NUMBER	QTY	DESCRIPTION
1	V42-I40DL04401	1	Chuck Flange
2	V42-5DL05402	1	Chuck Body
3	V42-5DL05403	1	Collet Seat
4	V42-5DL05404	1	Drawbar Adapter (separate item)*
5	V42-5DL05405	1	Coupling Stop
6	V42-5DL05406	1	Part Stop
7	V42-5DL05407	6	Spacer
8	V42-00201	1	Key for Collet Seat
9	V42-01007	1	Key for Collet Head
10	V42-5DL05410	1	Part Stop Wrench
15	CE-0006003	1	O-Ring 60mm ID, 3mm C's
16	OR-0004650	1	O-Ring 27/8 ID, 1/8mm C's
17	036911701	1	Seal
18	MS0103831	6	M8 x 90 SHCS (30ft-lb/41Nm)
19	MS0313617	1	M6 x 16 Flat Head Screw
20	MS0104018	4	M10 x 20 SHCS (40ft-lb/54Nm)
21	MS0103622	6	M6 x 40 SHCS
22	MS0103628	2	M6 x 70 SHCS

* No additional charge unless a drawbar linkup is required.

Installation

The spindle adapter and collet seat assembly are shipped assembled. The spindle adapter must be separated from the body by removing the six mounting screws #18. Inspect the six fastening screws #21 to ensure a torque of 7.375 ft-lb (10Nm). Tighten if necessary.

Clean, inspect and grease the machine spindle and the spindle adapter. Mount the spindle adapter to the machine spindle using the four fastening screws #20. For A2 style spindles, orient the spindle adapter with the drive button. Tighten the fastening screws to the appropriate torque shown in the parts list. Flat back spindle adapter must be indicated before you torque the bolts to specification.

Check the concentricity and face runout of the spindle adapter before mounting the collet seat assembly. Neither should exceed .0002" (5µm). If the indicator reading is more than .0002" (5µm), remove the spindle adapter and clean the surfaces again before remounting.

Reduce the clamping pressure of the machine to a minimum and extend the drawbar to the forward position. Carefully screw the collet seat assembly onto the drawbar clockwise until it bottoms out. **DO NOT TIGHTEN.** Rotate the body counterclockwise until the clearance holes in the body line up with the threaded holes on the spindle adapter. Carefully move the drawbar backwards and seat the collet seat assembly into the spindle adapter. Insert and tighten the six mounting screws #18 equally to 30 ft-lb (41Nm) torque.

Increase the clamping pressure to sufficient force for the job.

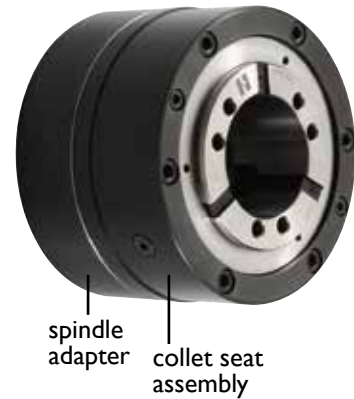

Checking the Final Concentricity of the Collet Closing Taper

Locate the probe to touch the inside closing taper of the body to verify concentricity. This should not exceed .0006" (15µm). If the indicator reading is more than .0006" (15µm), remove the body and clean the surfaces of the spindle adapter and the body again before remounting. Check the concentricity again and repeat this step until the desired reading is met. Concentricity may be affected if using stock beyond the nominal gripping range.

Installing a Collet Head

Installing or changing of the collet head is possible only when the chuck is in the unclamped position. Prior to inserting the collet head you must clean the taper of the collet seat and the mating taper of the collet head.

Fully insert the pins of the manual wrench into the holes in the face of the collet head. Actuate or pull the lever to collapse the segments before inserting it into the collet seat. Insert applying light pressure. Orient the keyway in the collet head with the key #9 in the collet seat. To release the collet head from the manual wrench you must press on the release button.

CAUTION: When actuating the manual wrench never reach inside the moving parts where there is risk of injury to your hand. Clean and lightly oil the collet head and the body before installing.



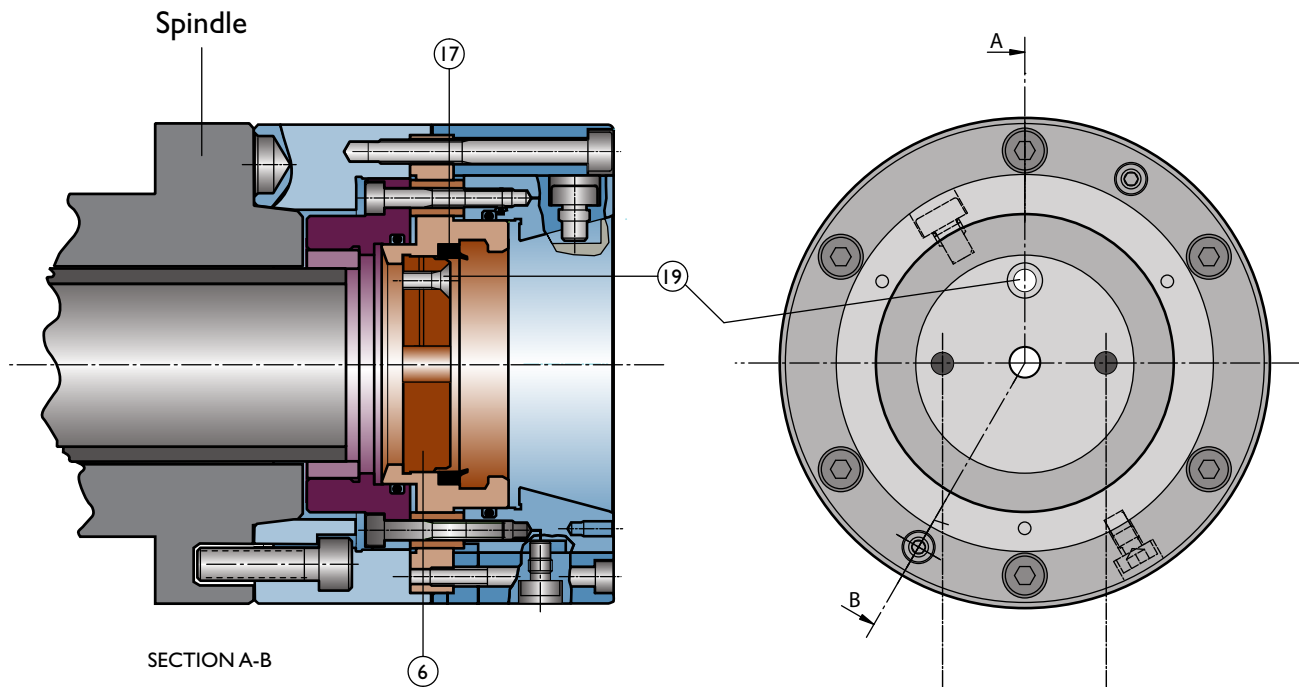

Removing or Changing the Work Stop

Follow the previous instructions to remove the collet head before changing the work stop. The collet head must be in the unclamp position. Reach in and remove the seal #17 and set it aside.

Turn the locking screw #19 counterclockwise to loosen the threads to allow the removal of the work stop #6. It is not necessary to remove the locking screw.

A work stop wrench #10 is supplied with the spindle mount assembly to remove the work stop. Align and insert the pins of the wrench into the holes in the face of the work stop. Turn the wrench counterclockwise to unscrew the work stop. If you feel resistance you must go back and loosen the locking screw #19.

The work stop has an M12 thread in the center to secure a custom work stop for required workpiece applications.

To reassemble, simply follow the same instructions in reverse order. Insert the work stop with the two pin holes facing out. Tighten the locking screw by hand to ensure that there will be no movement in the dead-length® work stop. Remember to replace the seal #17 before inserting your collet head. Failure to use the seal may cause malfunction of the collet system.

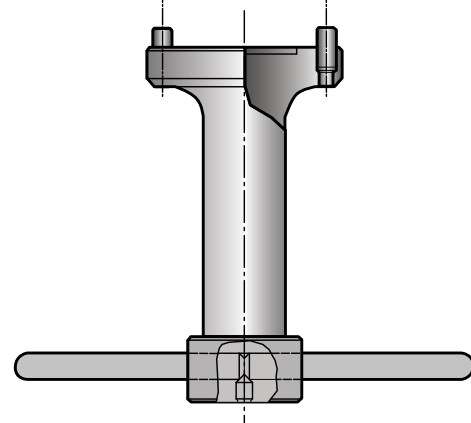

⑩ PART STOP WRENCH