

Mounting Instructions for 20C-to-16C and 25C-to-16C Spindle Collet Adapters for Hardinge 20C and 25C Spindle Lathes

1. Remove any collet or step chuck which may be in the lathe spindle.
2. Remove any spindle-mounted device (step chuck closer; jaw chuck, expansion collet mount, face plate, etc.) which may be on the machine.
3. Thoroughly clean inside the spindle, as well as the spindle mount locating surfaces, to remove all chips, grit and coolant. Use a lint-free cloth to insure the surfaces are completely free of lint.
4. Use Die Maker's Grease and coat all surfaces.
5. Remove the draw tube from the spindle of the lathe. (Refer to the Operator's Manual for your lathe to obtain instructions for this procedure.)
6. Clean the threads in the draw tube and on the Draw Tube Adapter. Coat the threads with Die Maker's Grease.
7. Put the draw tube in a vise with soft or copper jaws. Grip the tube just behind the collet threads.
8. Firmly tighten the Draw Tube Adapter into the machine draw tube using a spanner wrench or a piece of 1/4" round stock.
9. Replace the draw tube in the lathe per the instructions in the Operator's Manual.
10. Actuate the collet closer to its full forward position.
11. Insert the Reducer Bushing into the spindle. This bushing slides over the Draw Tube Adapter inside the spindle.
12. Mount the Adapter Cap on the spindle, orienting as shown on the face of the cap. Tighten the four mounting Bolts.
13. Insert the 16C collet & turn the draw tube to catch the collet threads. Adjust the collet using the methods outlined in the lathe Operator's Manual.

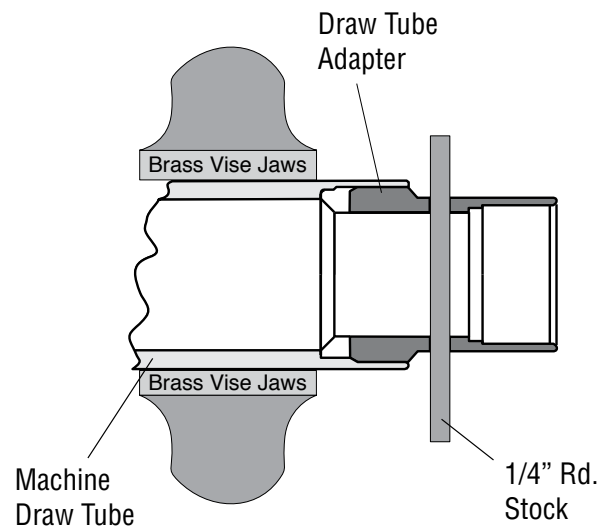

Tighten the Draw Tube Adapter while held in a soft jaw vise

NOTE: Do not Exceed 7,000 Lbs. draw force.

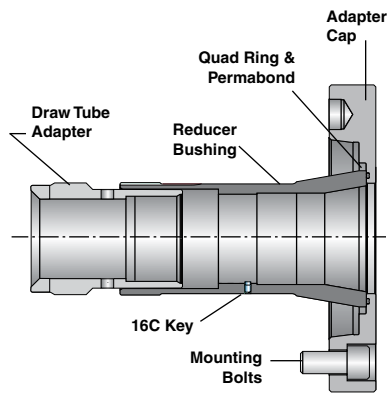

Spindle Collet Adapter Parts Lists

Description	A2-6 Spindle 20C to 16C Part Number	A2-6 QUEST® 25C to 16C Part Number	A2-8 Spindle 25C to 16C Part Number
Adapter Assembly - including:	7535-00-00	2993-00-00	7457-00-00
— Draw Tube Adapter	7541-00-00	7463-00-00	7463-00-00
— Reducer Bushing	7537-00-00	7461-00-00	7461-00-00
— Bolts [4]	MS-0104219	MS-0104219	MS-0104620
— Adapter Cap	7543-00-00	7543-00-00	7459-00-00
— Quad Ring	41-0011151-45	41-0011151-45	41-0011151-45
— Key	7539-00-00	7465-00-00	7465-00-00
— Permabond 910	QC-0010884	QC-0010884	QC-0010884

If the 16C collet cannot be removed:

If the collet cannot be removed, the Draw Tube Adapter has unthreaded from the Draw Tube. This problem is extremely rare, but if it does happen, a special tool must be made to extract the adapter. Any other method of extraction may damage the spindle and spindle assemblies. The "Extractor" must be fabricated using the sketch below. This assembly is not manufactured by Hardinge.

Specifications for making an "Extractor"

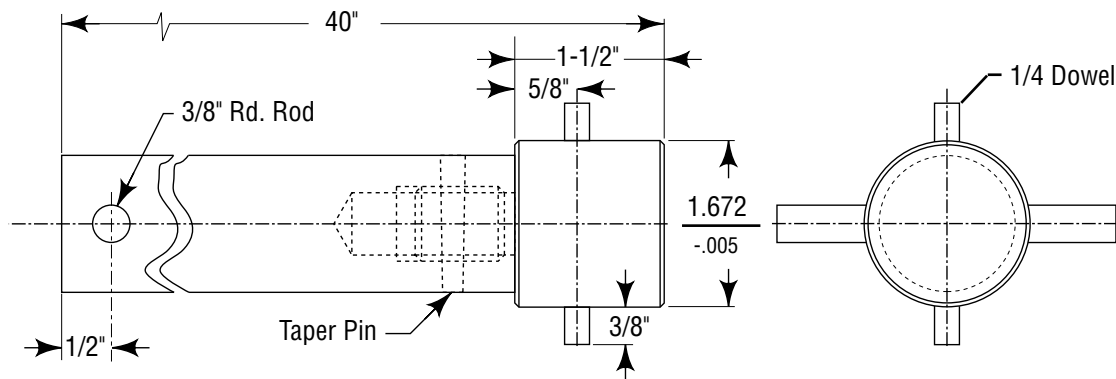

- Remove the machine draw tube. (Refer to the lathe's Operator's Manual for instructions).
- The tool is inserted from the back of the spindle.
- Align the two 1/4" pins on the "Extractor" with the slots in the back end of the Draw Tube Adapter.
- Turn the "Extractor" counter-clockwise until the Draw Tube Adapter comes loose from the 16C collet.
- Remove the "Extractor" and the Draw Tube Adapter from the back of the spindle.
- Re-mount the Draw Tube Adapter to the draw tube as instructed on the reverse side of this instruction sheet.
- Before re-assembly, it is recommended that the complete Spindle Adapter Assembly be removed from the lathe spindle. All the parts should be cleaned due to the possibility of contamination from chips during the removal of the Draw Tube Adapter.

